

THIS COPY IS PROVIDED ON A RESTRICTED BASIS AND IS NOT TO BE USED IN ANY WAY DETRIMENTAL TO THE INTERESTS OF PANDUIT CORP.

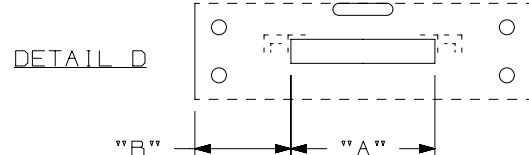

STYLE A

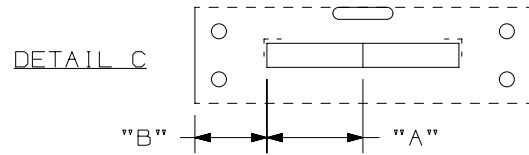
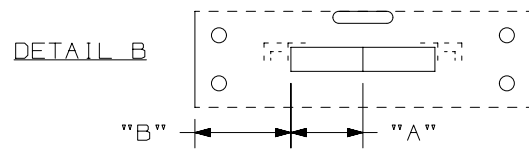
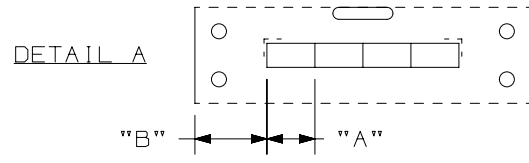
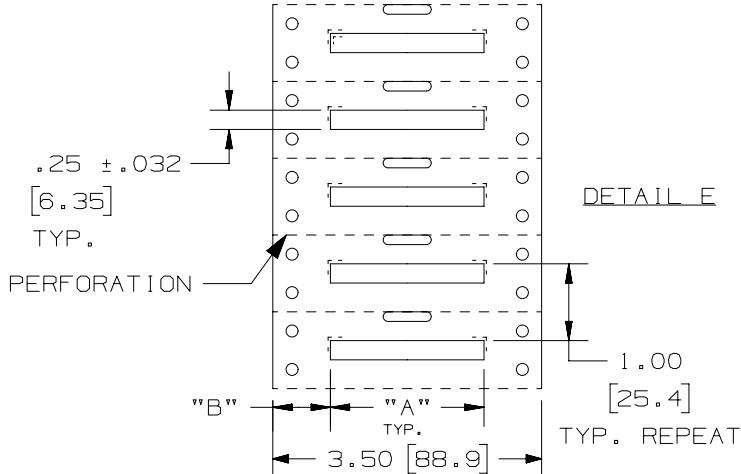
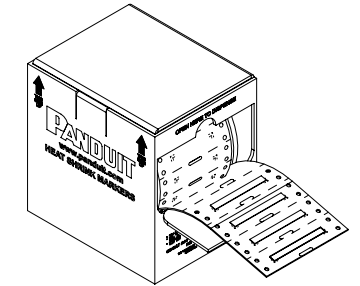

STYLE B

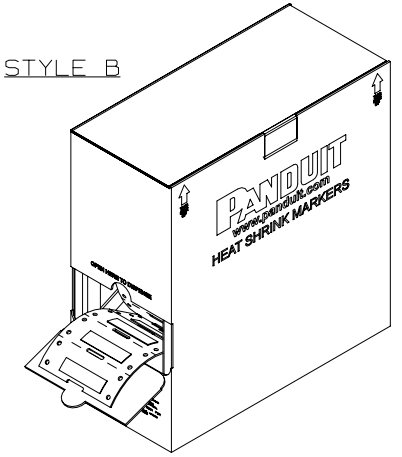

NOTE:
1. DIMENSIONS IN [] ARE IN MILLIMETERS.

PART NUMBER	SEE DETAIL	"A" +/- .062	"B"	MARKER ACROSS	TUBING COLOR	SEE STYLE	MARKERS PER ROLL
H050X025H1T	A	0.50 [12.70]	.75 [19.1]	4	WHITE	A	2000
H075X025H1T	B	0.75 [19.05]	1.00 [25.4]	2			1000
H100X025H1T	C	1.00 [25.40]	.75 [19.1]	2			1000
H150X025H1T	D	1.50 [38.10]	1.00 [25.4]	1	YELLOW	A	500
H200X025H1T	E	2.00 [50.80]	.75 [19.1]	1			500
H050X025H2T	A	0.50 [12.70]	.75 [19.1]	4			2000
H075X025H2T	B	0.75 [19.05]	1.00 [25.4]	2	BLACK	A	1000
H100X025H2T	C	1.00 [25.40]	.75 [19.1]	2			1000
H150X025H2T	D	1.50 [38.10]	1.00 [25.4]	1			500
H200X025H2T	E	2.00 [50.80]	.75 [19.1]	1	RED	A	500
H050X025H3T	A	0.50 [12.70]	.75 [19.1]	4			2000
H075X025H3T	B	0.75 [19.05]	1.00 [25.4]	2			1000
H100X025H3T	C	1.00 [25.40]	.75 [19.1]	2	WHITE	B	1000
H150X025H3T	D	1.50 [38.10]	1.00 [25.4]	1			500
H200X025H3T	E	2.00 [50.80]	.75 [19.1]	1			500
H050X025H1T-B	A	0.50 [12.70]	.75 [19.1]	4			10000
H075X025H1T-B	B	0.75 [19.05]	1.00 [25.4]	2			5000
H100X025H1T-B	C	1.00 [25.40]	.75 [19.1]	2			5000
H150X025H1T-B	D	1.50 [38.10]	1.00 [25.4]	1			2500
H200X025H1T-B	E	2.00 [50.80]	.75 [19.1]	1			2500

REV	DATE	BY	CHK	APR	DESCRIPTION	ECN
9	4/28/15	RVU	SEWH	JHAC	ADD NEW COLUMN OF MARKERS PER ROLL.	GAECN02781
8	1/19/15	RVU	SEWH	MSAD	REVISED TO CURRENT PANDUIT LOGO.	GAECN02539
7	4/12/12	RVU			REVISED H150 PARTS TO SHOW ALL MARKERS ARE ONLY 1.5" LONG.	6731
6	5/21/09	RVU			+/- .12, +/- .062, +/- .020 WAS +/- .03, +/- .032, +/- .010. HT: .25 +/- .032 WAS .250. MAT'L, HSK TUBING GMUHS31, 3.5 WIDE LINER WAS GMUHS. ADD "A" +/- .062. ADD STYLE B VIEW FOR BULK BOX. UPDATE VIEWS.	5593

TITLE					
H***X025H*T OPTIMUM COMPUTER PRINTABLE MIL. SPEC. HEAT SHRINK MARKERS CUSTOMER DRAWING					
ITEM REVISION NAME			100923NG/11		
DATASET FILE NAME			100923NG_DC_C10432/11K		
UNLESS OTHERWISE SPECIFIED, DIMENSIONAL TOLERANCES ARE: IN [mm]					
.x ± .12 [3.05]		.xxx ± .020 [0.508]		MATERIAL:	
.xx ± .062 [1.57]		ANGLES ±		HEATSHRINK TUBING GMUHS31, 3.5 WIDE LINER	
				DRAWING NUMBER:	
THIRD ANGLE PROJECTION				C10432	
DRAWN BY	DATE	CHK	SCALE	SIZE	
RVU	8/1/06	MSAD	NTS	SHT 1 OF 1 A	