

THIS DRAWING IS UNPUBLISHED. RELEASED FOR PUBLICATION
 © COPYRIGHT - By - ALL RIGHTS RESERVED.

LOC	DIST	REVISIONS			
P	LTR	DESCRIPTION	DATE	DWN	APVD
G	14	F3	REVISED PER ECO-12-014453	13SEP12	KH DR

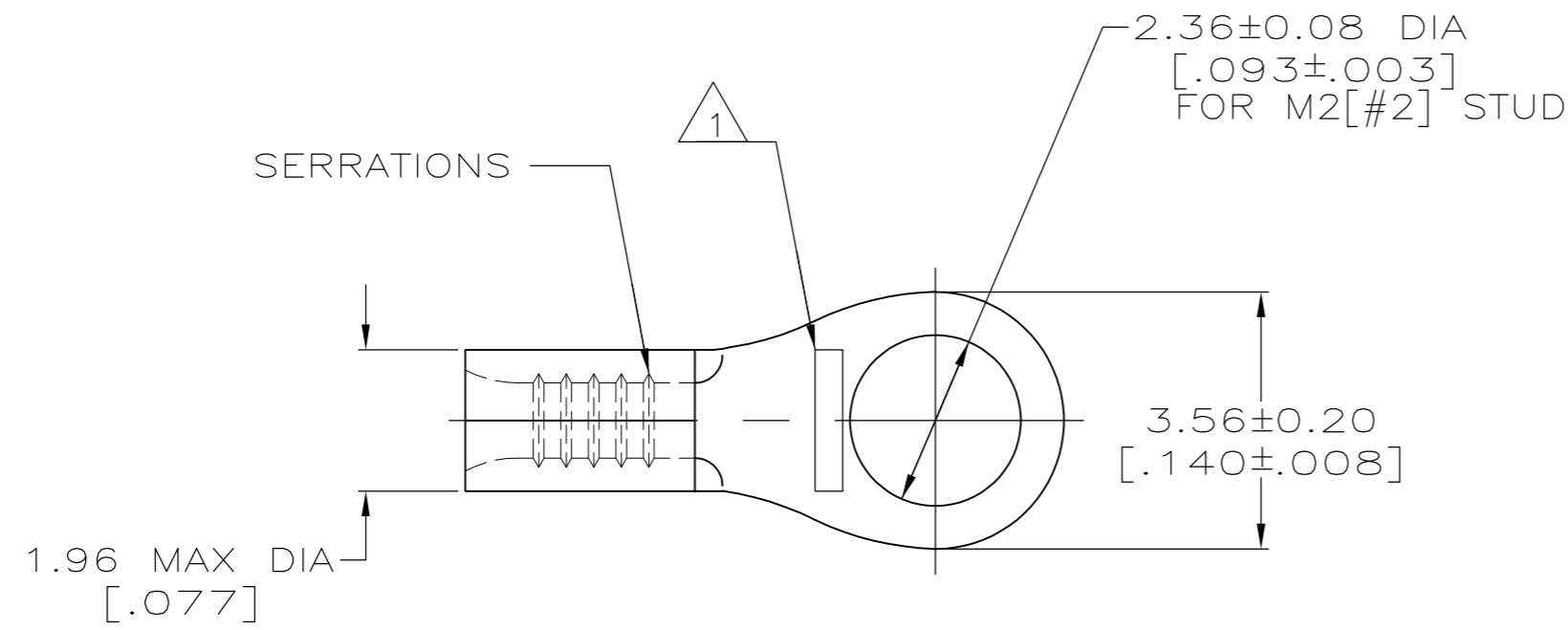

- 1 STAMP AMP APPROX AS SHOWN
- 2 TIN PLATE 0.00254 $[\text{.000100}]$ MIN THK PER ASTM B-545
- 3 NICKEL PLATE 0.00762 $[\text{.000300}]$ MIN THK PER QQ-N-290
- 4 COPPER PER ASTM B-152, ANNEALED
- 5 NOTE DELETED
- 6 NO PLATING/BARE COPPER

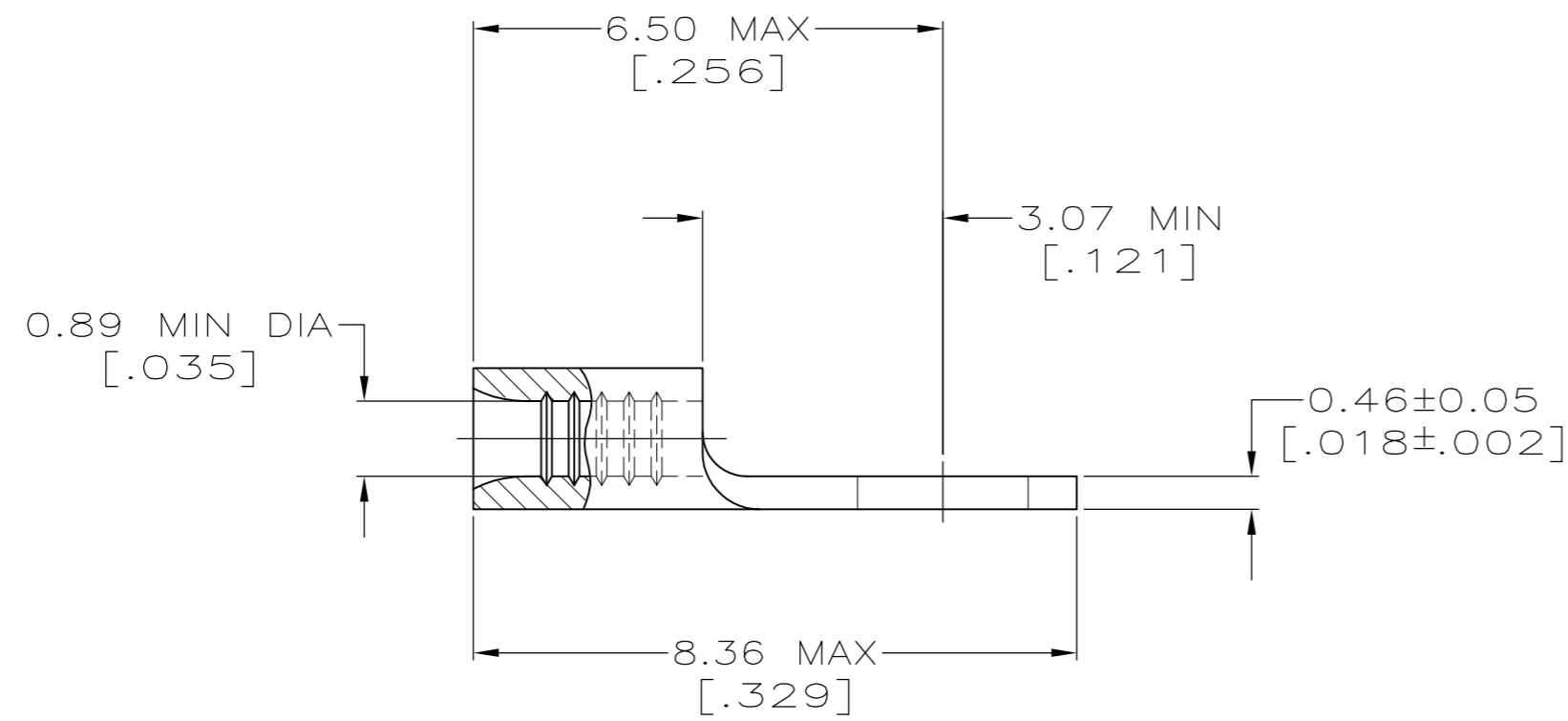

QTY	FINISH	PACKAGING	PART NO
---	3	LOOSE PIECE	2-31425-3
5000	2	ON TAPE	2-31425-2
PRELIMINARY	1000	LOOSE PIECE	31425-1
---	2	LOOSE PIECE	31425

AMP INCORPORATED CUSTOMER SERVICE SYSTEMS		MAX RECOMMENDED OPERATING TEMPERATURE: 170°C [338°F]
FOR ADDITIONAL PRODUCT INFORMATION OR COPIES OF DRAWINGS AND TECHNICAL DOCUMENTS	PRODUCT INFORMATION CENTER 1-800-522-6752	VOLTAGE RATING: N/A
FOR APPLICATION TOOLING INFORMATION	TOOLING ASSISTANCE CENTER 1-800-722-1111	CIRCULAR MIL AREA: 0.1-0.41mm ² [202-810] STRANDED
FOR ORDER ENTRY	1-800-526-5142	THIS DRAWING IS A CONTROLLED DOCUMENT FOR AMP INCORPORATED. IT IS SUBJECT TO CHANGE AND THE CONTROLLING ENGINEERING ORGANIZATION SHOULD BE CONTACTED FOR THE LATEST REVISION.

THIS DRAWING IS A CONTROLLED DOCUMENT.		DWN TA BRINKMAN 2-2-93	TE TE Connectivity	
DIMENSIONS: mm [INCHES]		CHK DA PATTERSON 2-2-93		
TOLERANCES UNLESS OTHERWISE SPECIFIED:		APVD DA PATTERSON 2-2-93	NAME TERMINAL, RING TONGUE, BUDGET WIRE SIZE 26-22 AWG	
0 PLC ± - 1 PLC ± - 2 PLC ± - 3 PLC ± - 4 PLC ± - ANGLES ± -		PRODUCT SPEC -	SIZE A2	
MATERIAL COPPER 4		FINISH SEE TABLE	CAGE CODE 00779	DRAWING NO C-31425
		WEIGHT -	RESTRICTED TO -	SCALE 10:1
		CUSTOMER DRAWING	SHEET 1 OF 1	REV F3