

REV C 1062-20-06* *

REVISIONS			
SYM	DESCRIPTION	DATE	APPROVED
NC	NEW RELEASE PER E.O. P19553	6-25-07	R.D.R.
A	RELEASE PER E.O. P19675	1-29-08	R.D.R.
B	RELEASE PER E.O. P19866	6-26-08	R.D.R.
C	RELEASE PER E.O. P20392	12-3-09	RDR

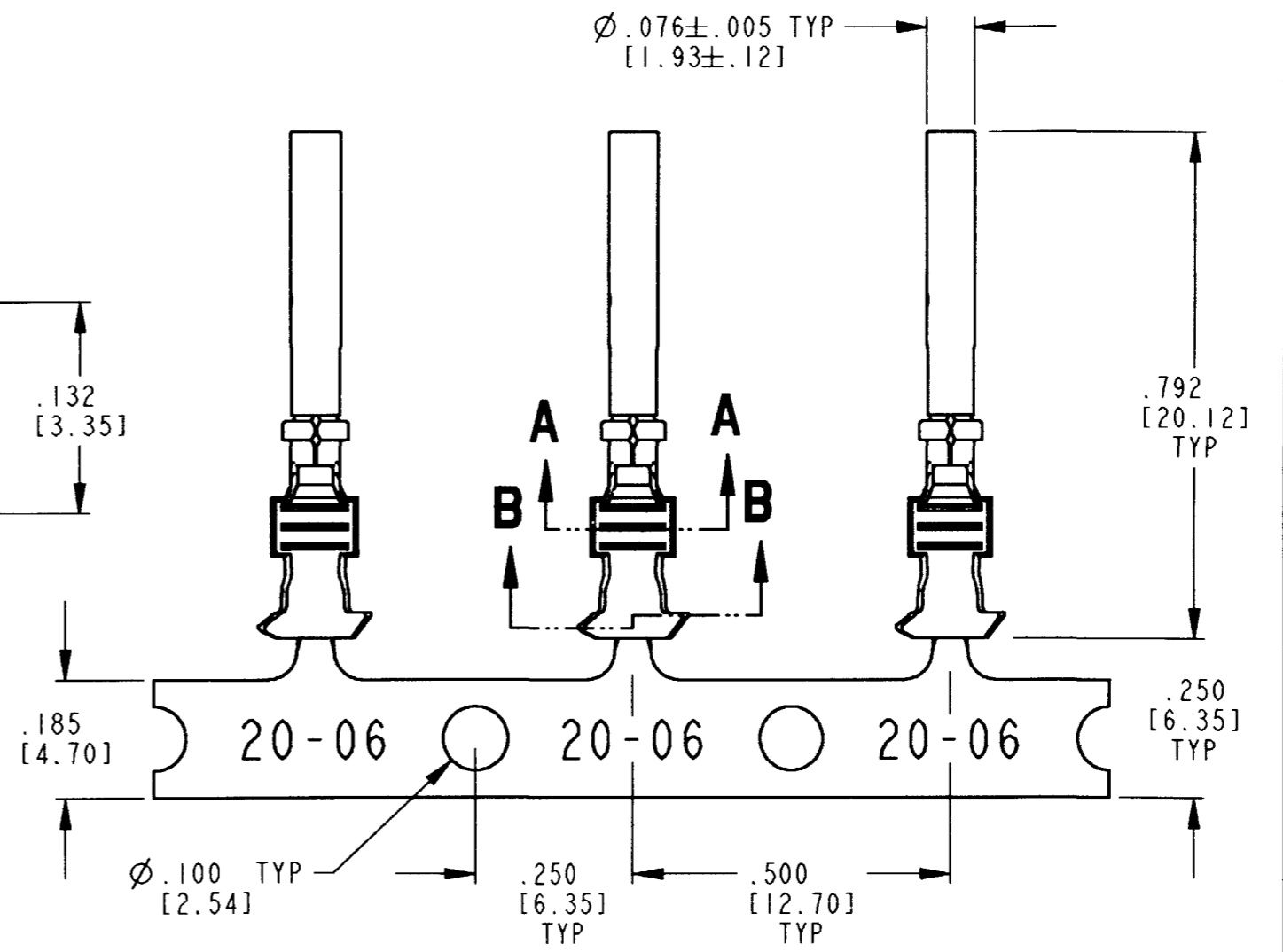

7. CONTACT BODY MATERIAL: COPPER ALLOY;
CONTACT SLEEVE MATERIAL: STAINLESS STEEL.
 6. WHEN ** = 22 PLATING IS NICKEL.
 ** = 44 PLATING IS GOLD.
 ** = 77 PLATING IS TIN.
 5. SEE 0425-015-0000 FOR CONTACT PERFORMANCE AND WIRE APPLICATION CHARACTERISTICS.
 4. THIS CONTACT MAY BE CRIMPED WITH DCT20-02-00 OR DTC1620-02-00 AUTOMATIC DIE OR DTT-20-03 HAND TOOL. SEE DRAWING 0425-207-0000 OR 0425-059-0000 FOR APPLICABLE WIRE SIZE, INSULATION DIAMETER RANGE, AND CRIMPING INFORMATION.
 3. ONE REEL CONTAINS APPROXIMATELY 4000 CONTACTS.
 2. DIMENSIONAL TOLERANCE: ±.025 [0.64].
 1. DIMENSIONS ARE IN INCHES [mm].
- NOTES: UNLESS OTHERWISE SPECIFIED

SIGNATURE & DATE	
DR	J. APOSTOL 30MAY2007
CHK	Dmax 12/2/09
PE	Dmax 12/2/09
APPD	R. Rued 12-3-09
SCALE	NONE
WT	

STAMPED CONTACT SOCKET SIZE 20
ENVELOPE

EP 178	MATL. CODE
3850 INDUSTRIAL AVE. HEMET, CA 92545	
B 1062-20-06* *	
DWG SIZE	CODE 11139 SHEET OF