

# Customer Information Sheet

DRAWING No.: S7221-45R

IF IN DOUBT - ASK

©

NOT TO SCALE

THIRD ANGLE PROJECTION

ALL DIMENSIONS IN mm

- NOTES:  
 1. QUANTITY PER REEL = 10,000.  
 2. THIS PRODUCT IS TAPED AND REELED IN GENERAL ACCORDANCE WITH EIA-481-2 (ELECTRONICS INDUSTRIES ASSOCIATION).

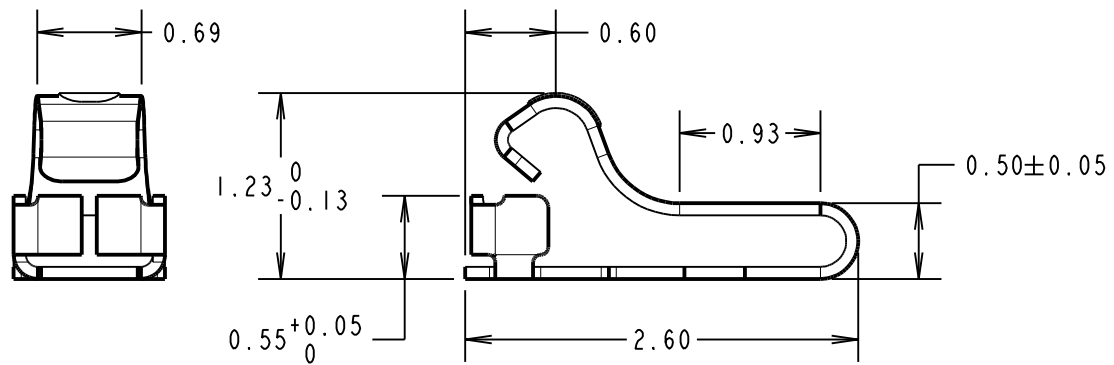
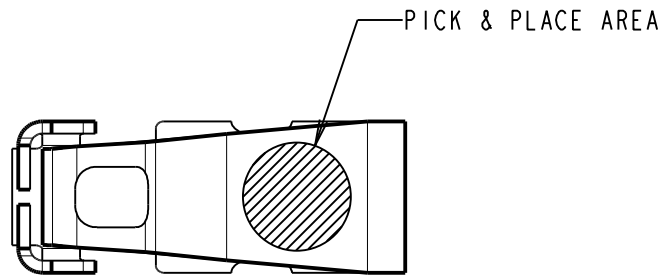
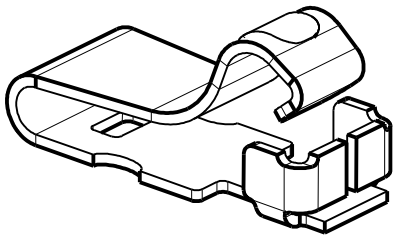
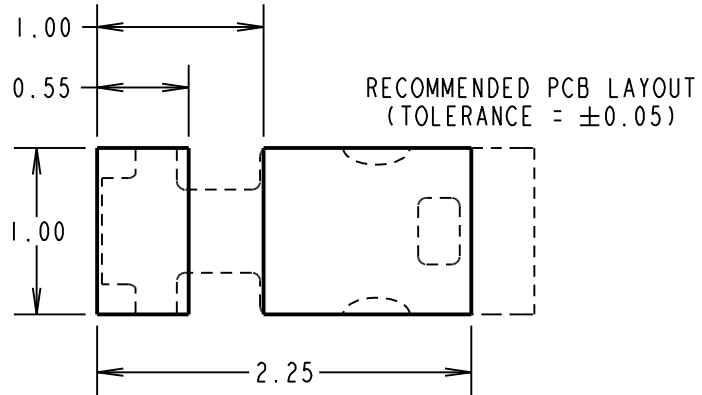

COMPONENT DETAILS

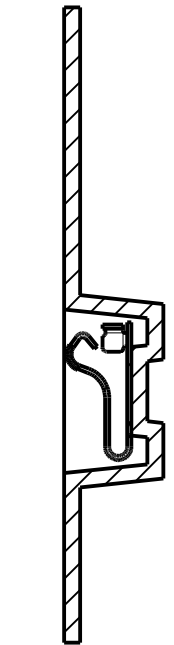
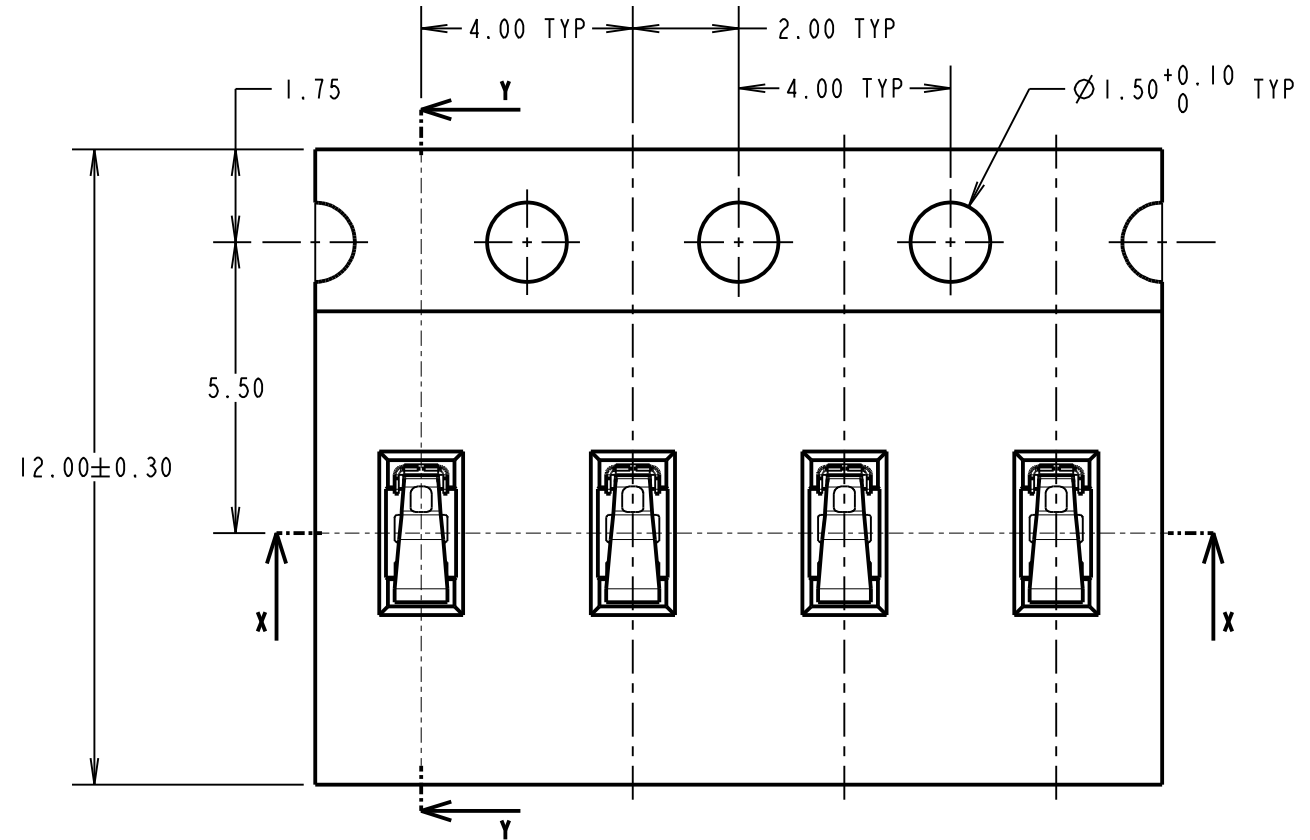
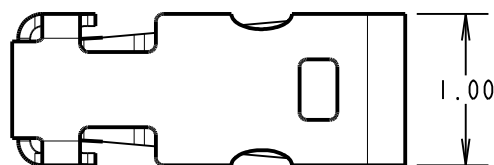

SECTION Y-Y

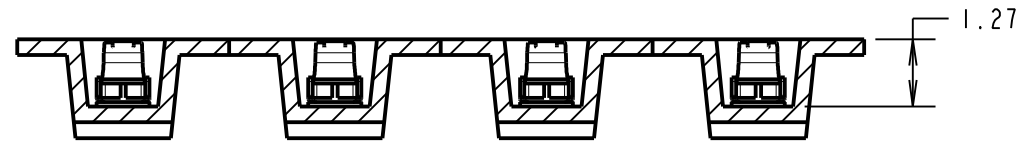

SECTION X-X

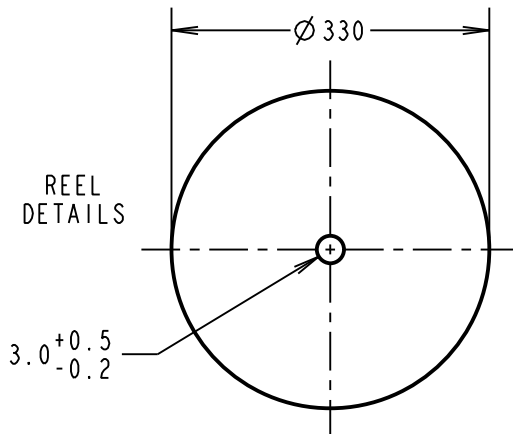

REEL DETAILS

SPECIFICATION:  
 MATERIAL = TITANIUM COPPER ALLOY, 0.08mm THICK  
 FINISH = 1.5 $\mu$ -3.5 $\mu$  NICKEL ALL OVER, 0.1 $\mu$  GOLD ON TOP  
 CONTACT AREA AND GOLD FLASH ON BASE  
 ELECTRICAL:  
 CONTACT RESISTANCE = 50m $\Omega$  MAX  
 CURRENT RATING = 1A  
 VOLTAGE RATING = 250V AC  
 MECHANICAL:  
 DURABILITY = 10,000 CYCLES  
 RECOMMENDED WORKING HEIGHT = 0.90mm / MIN FORCE = 0.39N  
 RECOMMENDED MINIMUM WORKING HEIGHT = 0.63mm  
 ENVIRONMENTAL:  
 OPERATING TEMPERATURE = -40°C TO +85°C

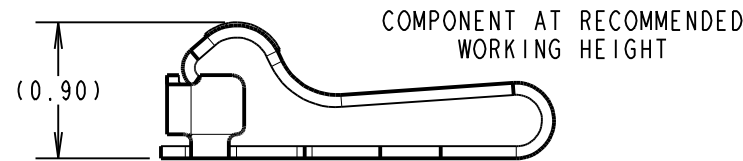
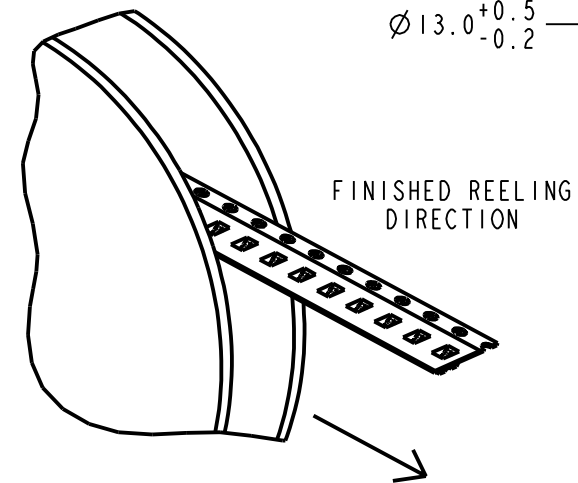

COMPONENT AT RECOMMENDED WORKING HEIGHT

MSP	2	30.11.15	13179
NAME	ISS.	DATE	C/NOTE
APPROVED:		M. PERREN	
CHECKED:		S. BENNETT	
DRAWN:		S. BENNETT	
CUSTOMER REF.:			
ASSEMBLY DRG:			

**HARWIN**

www.harwin.com  
 technical@harwin.com

THIS DRAWING AND ANY INFORMATION OR DESCRIPTIVE MATTER SET OUT HEREON ARE CONFIDENTIAL AND COPYRIGHT PROPERTY OF THE HARWIN GROUP AND MUST NOT BE DISCLOSED, LOANED, COPIED OR USED FOR MANUFACTURING, TENDERING OR FOR ANY OTHER PURPOSE WITHOUT THEIR WRITTEN PERMISSION.

TOLERANCES  
 X. =  $\pm 1$ mm  
 X.X =  $\pm 0.50$ mm  
 X.XX =  $\pm 0.10$ mm  
 X.XXX =  $\pm 0.01$ mm  
 ANGLES =  $\pm 5^\circ$   
 UNLESS STATED

MATERIAL:  
 SEE ABOVE  
 FINISH: SEE ABOVE  
 S/AREA: mm<sup>2</sup>

TITLE: SMT SPRING CONTACT  
 (1.23mm HIGH)  
 IN TAPE AND REEL

DRAWING NUMBER:  
**S7221-45R**

SHT  
 2 OF 2