

LV5680NPVC

Linear Voltage Regulator, Multiple-Output, System Power Supply IC, for Automotive Infotainment System



ON Semiconductor®

www.onsemi.com

Overview

The LV5680NPVC is a multi-power supply system IC that provides four regulator outputs and two high side switches as well as a number of protection functions including overcurrent protection, overvoltage protection and overheat protection. It is an optimal power supply IC for car audio and car entertainment systems and similar products.

Features

- Four regulator output systems
 - For microcontroller: 5.0V output voltage, 200mA maximum output current
 - For CD drive: 8.0V output voltage, 1300mA maximum output current
 - For illumination: 8 to 12V output voltage (output can be set with external resistors), 300mA maximum output current
 - For audio systems: 8 to 9V output voltage (output voltage can be set with external resistors), 300mA maximum output current
- Two V_{CC}-linked high side switch systems
 - EXT: 350mA maximum output current, 0.5V voltage difference between input and output.
 - ANT: 300mA maximum output current, 0.5V voltage difference between input and output.
- Two V_{DD} 5V-linked high side switch systems
 - SW5V: 200mA maximum output current, 0.2V voltage difference between input and output.
 - ACC (accessory voltage detection output): 100mA maximum output current, 0.2V voltage difference between input and output.
- Overcurrent protection function
- Overvoltage protection function, typ 21V (excluding V_{DD} 5V output)
- Overheat protection function, typ 175°C
- On-chip accessory voltage detection circuit
- P-channel LDMOS used for power output block

(Warning) The protector functions only improve the IC's tolerance and they do not guarantee the safety of the IC if used under the conditions out of safety range or ratings. Use of the IC such as use under over current protection range or thermal shutdown state may degrade the IC's reliability and eventually damage the IC.

Typical Applications

- Automotive infotainment

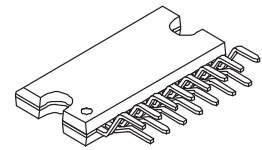

HZIP15J

GENERIC MARKING DIAGRAM

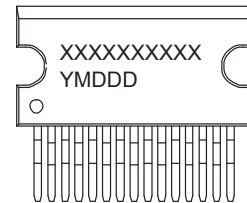

XXXXXX = Specific Device Code
Y = Year
M = Month
DDD = Additional Traceability Data

ORDERING INFORMATION

Ordering Code:
LV5680NPVC-XH

Package
HZIP15J
(Pb-Free / Halogen Free)

Shipping (Qty / packing)
20 / Fan-Fold

LV5680NPVC

Specifications

Absolute Maximum Ratings at $T_a = 25^\circ\text{C}$ (Note 1)

Parameter	Conditions	Conditions	Ratings	Unit	
Supply voltage	V_{CC} max		36	V	
Peak supply voltage	V_{CC} peak	See below for the waveform applied.	50	V	
Allowable Power dissipation	P_d max	Independent IC	$T_a \leq 25^\circ\text{C}$	1.5	W
		Al heat sink (Note 2)		5.6	W
		With an infinity heat sink		32.5	W
Junction temperature	T_j max		150	$^\circ\text{C}$	
Operating ambient temperature	T_{opr}		-40 to +85	$^\circ\text{C}$	
Storage temperature	T_{stg}		-55 to +150	$^\circ\text{C}$	

1. Stresses exceeding those listed in the Maximum Rating table may damage the device. If any of these limits are exceeded, device functionality should not be assumed, damage may occur and reliability may be affected.

2. When the Aluminum heat sink (50mm × 50mm × 1.5mm) is used

Recommended Operating Ranges at $T_a = 25^\circ\text{C}$ (Note 3)

Parameter	Conditions	Ratings	Unit
Operating supply voltage 1	V_{DD} output, SW output, ACC output	7.5 to 16	V
Operating supply voltage 2	ILM output at 10V	12 to 16	V
	ILM output at 8V	10 to 16	V
Operating supply voltage 3	Audio output at 9V	10 to 16	V
Operating supply voltage 4	CD output (CD output current = 1.3A)	10.5 to 16	V
	CD output (CD output current ≤ 1 A)	10 to 16	V

3. Functional operation above the stresses listed in the Recommended Operating Ranges is not implied. Extended exposure to stresses beyond the Recommended Operating Ranges limits may affect device reliability.

Electrical Characteristics at $V_{CC} = 14.4\text{V}$, $T_a = 25^\circ\text{C}$ (Note 4,10)

Parameter	Symbol	Conditions	Ratings			Unit
			min	typ	max	
Current drain	I_{CC}	V_{DD} no load, CTRL1/2 = $\lceil L/L \rceil$, ACC = 0V		400	800	μA
CTRL1 Input						
Low input voltage	V_{IL1}		0		0.5	V
M1 input voltage	V_{IM1}		0.8	1.1	1.4	V
M2 input voltage	V_{IM2}		1.9	2.2	2.5	V
High input voltage	V_{IH1}		2.9	3.3	5.5	V
Input impedance	R_{IH1}		350	500	650	$\text{k}\Omega$
CTRL2 Input						
Low input voltage	V_{IL2}		0		0.5	V
M input voltage	V_{IM2}		1.1	1.65	2.1	V
High input voltage	V_{IH2}		2.5	3.3	5.5	V
Input impedance	R_{IH2}		350	500	650	$\text{k}\Omega$
V_{DD} 5V Output (Note 5) The V_{DD} 5V output supplies the output currents of SW 5V and ACC 5V.						
Output voltage 1	V_{O1}	$I_{O1} = 200\text{mA}$, I_{O7} , $I_{O8} = 0\text{A}$	4.75	5.0	5.25	V
Output voltage 2	V_{O1}'	$I_{O1} = 200\text{mA}$, $I_{O7} = 200\text{mA}$, $I_{O8} = 100\text{mA}$	4.75	5.0	5.25	V
Output total current	I_{to1}	$V_{O1} \geq 4.75\text{V}$, $I_{to1} = I_{O1} + I_{O7} + I_{O8}$	500			mA
Line regulation	ΔV_{OLN1}	$7.5\text{V} < V_{CC} < 16\text{V}$, $I_{O1} = 200\text{mA}$ (Note 6)		30	90	mV
Load regulation	ΔV_{OLD1}	$1\text{mA} < I_{O1} < 200\text{mA}$ (Note 6)		70	150	mV
Dropout voltage 1	V_{DROP1}	$I_{O1} = 200\text{mA}$ (Note 6)		1.0	1.5	V
Dropout voltage 2	V_{DROP1}'	$I_{O1} = 100\text{mA}$ (Note 6)		0.7	1.05	V
Dropout voltage 3	V_{DROP1}''	$I_{O1} + I_{O7} + I_{O8} = 500\text{mA}$		2.5	3.75	V
Ripple rejection	R_{REJ1}	$f = 120\text{Hz}$, $I_{O1} = 200\text{mA}$ (Note 6)	40	50		dB

Continued on next page.

LV5680NPVC

Continued from preceding page.

Parameter	Symbol	Conditions	Ratings			Unit
			min	typ	max	
CD Output ; CTRL2 = [H]						
Output voltage	V _{O2}	I _{O2} = 1000mA	7.6	8.0	8.4	V
Output current	I _{O2}	V _{O2} ≥ 7.6V	1300			mA
Line regulation	ΔV _{OLN2}	10.5V < V _{CC} < 16V, I _{O2} = 1000mA		50	100	mV
Load regulation	ΔV _{OLD2}	10mA < I _{O2} < 1000mA		100	200	mV
Dropout voltage 1	V _{DROP2}	I _{O2} = 1000mA		1.0	1.5	V
Dropout voltage 2	V _{DROP2'}	I _{O2} = 500mA		0.5	0.75	V
Ripple rejection	R _{REJ2}	f = 120Hz, I _{O2} = 1000mA	40	50		dB
AUDIO (8-9V) Output ; CTRL2 = [M]						
AUDIO_F pin voltage	V _{I3}		1.222	1.260	1.298	V
AUDIO_F pin inflow current	I _{IN3}		-1		1	μA
AUDIO output voltage 1	V _{O3}	I _{O3} = 200mA, R ₂ = 30kΩ, R ₃ = 5.6kΩ (Note 7)	7.65	8.0	8.35	V
AUDIO output voltage 2	V _{O3'}	I _{O3} = 200mA, R ₂ = 27kΩ, R ₃ = 4.7kΩ (Note 7)	8.13	8.5	8.87	V
AUDIO output voltage 3	V _{O3''}	I _{O3} = 200mA, R ₂ = 24kΩ, R ₃ = 3.9kΩ (Note 7)	8.6	9.0	9.4	V
AUDIO output current	I _{O3}		300			mA
Line regulation	ΔV _{OLN3}	10V < V _{CC} < 16V, I _{O3} = 200mA		30	90	mV
Load regulation	ΔV _{OLD3}	1mA < I _{O3} < 200mA		70	150	mV
Dropout voltage 1	V _{DROP3}	I _{O3} = 200mA		0.3	0.45	V
Dropout voltage 2	V _{DROP3'}	I _{O3} = 100mA		0.15	0.23	V
Ripple rejection	R _{REJ3}	f = 120Hz, I _{O3} = 200mA	40	50		dB
ILM (8-12V) Output ; CTRL1 = [M1]						
ILM_F pin voltage	V _{I4}		1.222	1.260	1.298	V
ILM output voltage 1	V _{O4}	I _{O4} = 200mA	11.4	12.0	12.6	V
ILM output voltage 2	V _{O4'}	I _{O4} = 200mA, R ₁ = 270kΩ (Note 8)	8.5	10.0	11.5	V
ILM output voltage 3	V _{O4''}	I _{O4} = 200mA, R ₁ = 100kΩ (Note 8)	6.8	8.0	9.2	V
ILM output current	I _{O4}	R ₁ = 270kΩ	300			mA
Line regulation	ΔV _{OLN4}	12V < V _{CC} < 16V, I _{O4} = 200mA, R ₁ = 270kΩ		30	90	mV
Load regulation	ΔV _{OLD4}	1mA < I _{O4} < 200mA		70	150	mV
Dropout voltage 1	V _{DROP4}	I _{O4} = 200mA		0.7	1.05	V
Dropout voltage 2	V _{DROP4'}	I _{O4} = 100mA		0.35	0.53	V
Ripple rejection	R _{REJ4}	f = 120Hz, I _{O4} = 200mA	40	50		dB
Remoto (EXT) ; CTRL1 = [M2]						
Output voltage	V _{O5}	I _{O5} = 350mA	V _{CC} -1.0	V _{CC} -0.5		V
Output current	I _{O5}	V _{O5} ≥ V _{CC} -1.0	350			mA
ANT remoto ; CTRL1 = [H]						
Output voltage	V _{O6}	I _{O6} = 300mA	V _{CC} -1.0	V _{CC} -0.5		V
Output current	I _{O6}	V _{O6} ≥ V _{CC} -1.0	300			mA
SW 5V Output ; CTRL2 = [M]						
Output voltage 1	V _{O7}	I _{O7} = 1mA, I _{O1} , I _{O8} = 0A (Note 9)	V _{O1} -0.25	V _{O1}		V
Output voltage 2	V _{O7'}	I _{O7} = 200mA, I _{O1} , I _{O8} = 0A (Note 9)	V _{O1} -0.45	V _{O1} -0.2		V
Output current	I _{O7}	V _{O7} ≥ 4.55	200			mA
ACC Detection ; ACC Integration 5V output						
ACC detection voltage	V _{TH8}		2.8	3.0	3.2	V
Hysteresis width	V _{HIS8}		0.2	0.3	0.4	V
Input impedance	Z _{I8}	(Pull-down resistance internal)	42	60	78	kΩ
ACC output voltage 1	V _{O8}	I _{O8} = 0.5mA, I _{O1} , I _{O7} = 0A (Note 9)	V _{O1} -0.25	V _{O1}		V
ACC output voltage 2	V _{O8'}	I _{O8} = 100mA, I _{O1} , I _{O7} = 0A (Note 9)	V _{O1} -0.45	V _{O1} -0.2		V
ACC output voltage	I _{O8}	V _{O8} ≥ 4.55	100			mA

4. Functional operation above the stresses listed in the Recommended Operating Ranges is not implied. Extended exposure to stresses beyond the Recommended Operating Ranges limits may affect device reliability.

LV5680NPVC

5. The V_{DD} 5V output also supplies the output currents of SW 5V and ACC 5V. Therefore, the current supply capability of the V_{DD} 5V output and its other electrical characteristics are affected by the output statuses of SW 5V and ACC 5V.
6. SW 5V and ACC 5V are not subject to a load.
7. When a component with a resistance accuracy of $\pm 1\%$ is used
 <Reference> When a component with a resistance accuracy of $\pm 0.5\%$ is used, V_{O3} is $8.67V \leq 9.0V \leq 9.33V$
8. When a component with a resistance accuracy of $\pm 1\%$ is used
 The absolute accuracy of the internal resistance is $\pm 15\%$
9. Since the SW 5V and ACC 5V are output from V_{DD} 5V through the SW, the voltage drops by an amount equivalent to the ON resistance of the SW.
10. The entire specification has been defined based on the tests performed under the conditions where T_j and T_a ($=25^\circ C$) are almost equal. There tests were performed with pulse load to minimize the increase of junction temperature (T_j).

• Allowable power dissipation derating curve

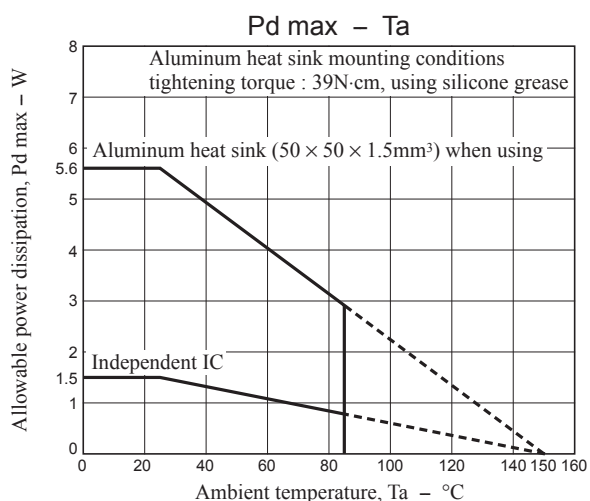

• Waveform applied during surge test

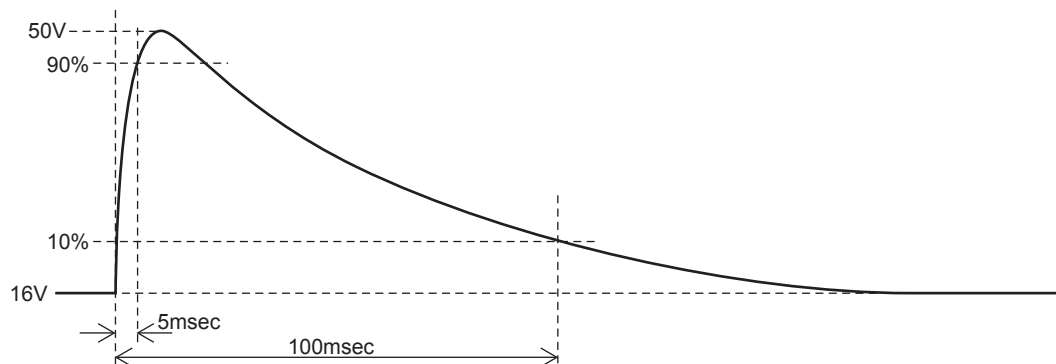

LV5680NPVC

Package Dimensions

unit : mm

HZIP15J
CASE 945AC
ISSUE A

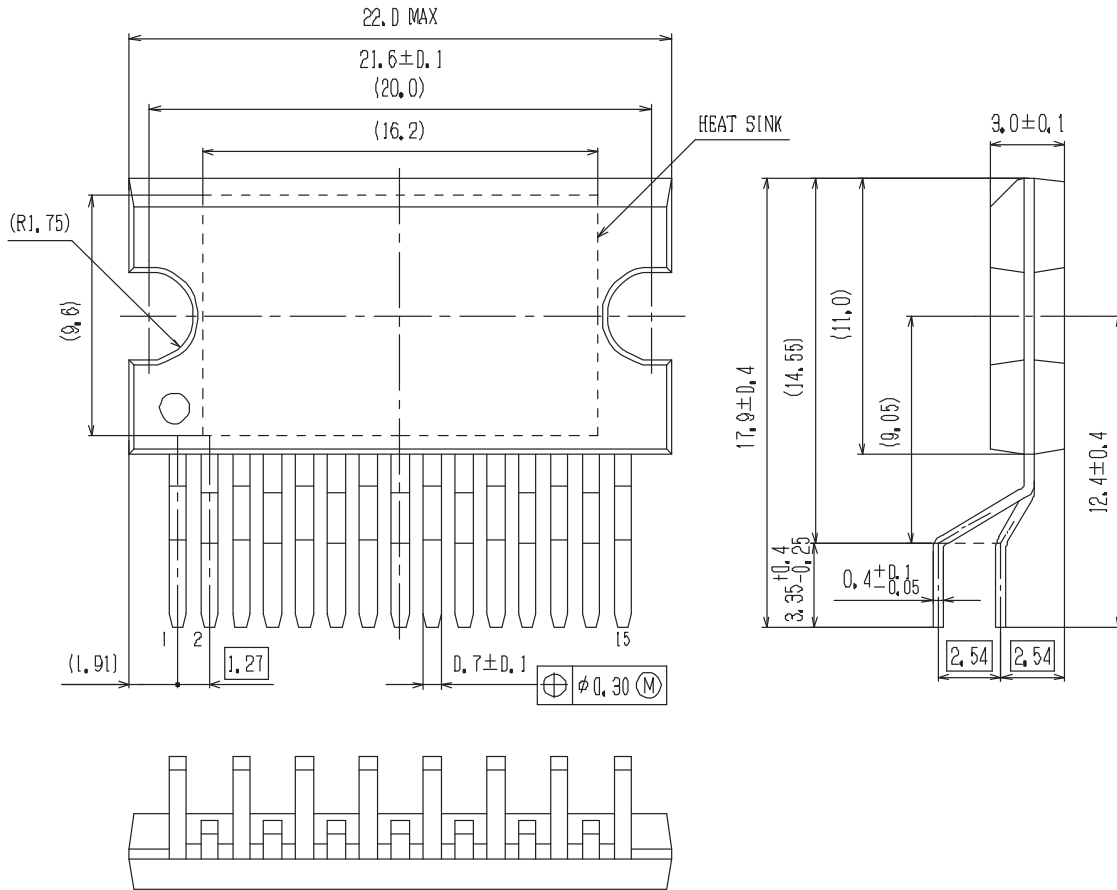

SOLDERING FOOTPRINT*

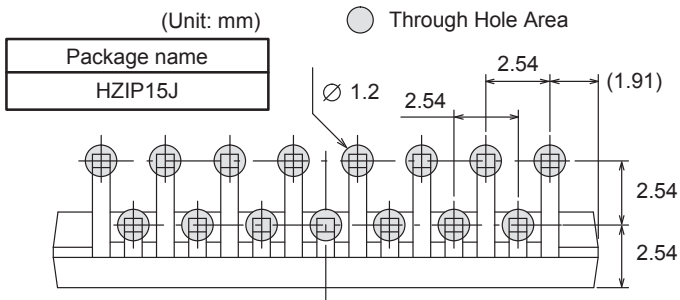

NOTE: The measurements are not to guarantee but for reference only.

*For additional information on our Pb-Free strategy and soldering details, please download the ON Semiconductor Soldering and Mounting Techniques Reference Manual, SOLDERRM/D.

LV5680NPVC

Block Diagram

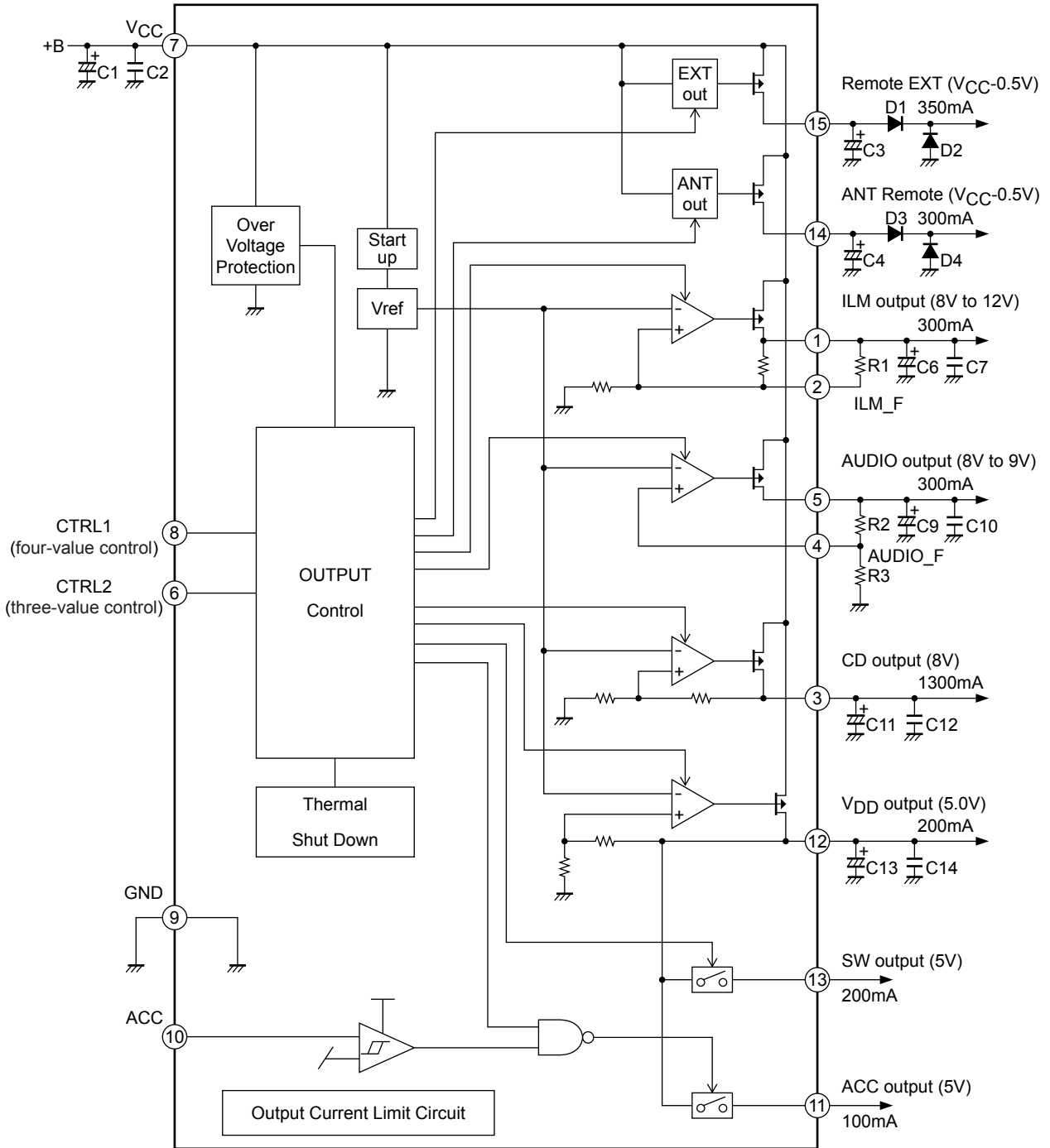

LV5680NPVC

Pin Function

Pin No.	Pin name	Description	Equivalent Circuit
1	ILM	ILM output pin ON when CTRL1 = M1, M2, H 12.0V/300mA	
2	ILM_F	ILM output voltage adjustment pin	
3	CD	CD output pin ON when CTRL2 = M, H 8.0V/1.3A	
4	AUDIO_F	AUIDO output voltage adjustment pin	
5	AUDIO	AUDIO output pin ON when CTRL2 = M, H	
6	CTRL2	CTRL2 input pin three-value input	
7	VCC	Supply terminal	

Continued on next page.

LV5680NPVC

Continued from preceding page.

Pin No.	Pin name	Description	Equivalent Circuit
8	CTRL1	CTRL1 input pin four-value input	
9	GND	GND pin	
10	ACC	Accessory input	
11	ACC5V	Accessory detection output ON when ACC > 3V	
12	V _{DD} 5V	V _{DD} 5V output pin 5.0V/200mA	
13	SW5V	SW5V output pin ON when CTRL2 = M, H	
14	ANT	ANT output pin ON when CTRL1 = H V _{CC} -0.5V/300mA	

Continued on next page

LV5680NPVC

Continued from preceding page.

Pin No.	Pin name	Description	Equivalent Circuit
15	EXT	EXT output pin ON when CTRL1 = M2, H $V_{CC}-0.5V/350mA$	

LV5680NPVC

CTRL Pin Output Truth Table

CTRL1	ANT	EXT	ILM
L	OFF	OFF	OFF
M1	OFF	OFF	ON
M2	OFF	ON	ON
H	ON	ON	ON

CTRL2	CD	AUDIO	SW5
L	OFF	OFF	OFF
M	OFF	ON	ON
H	ON	ON	ON

Timing Chart

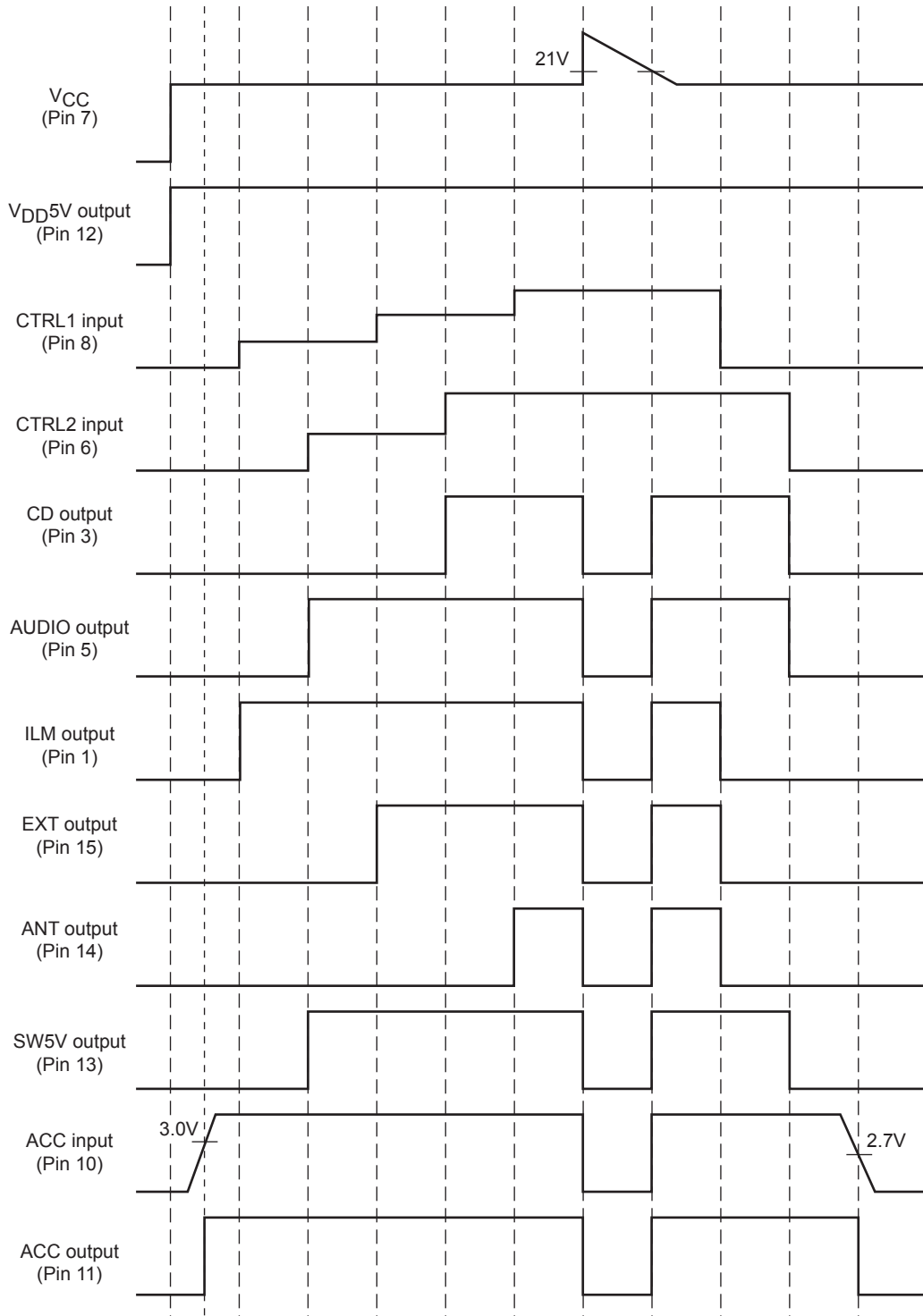

LV5680NPVC

Recommended Operation Circuit

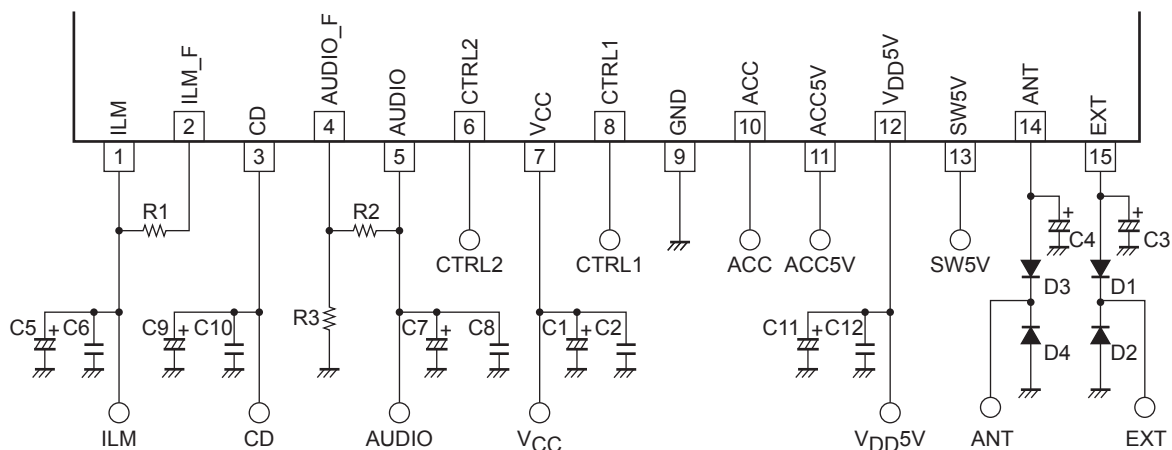

Peripheral parts list

Name of part	Description	Recommended value	Remarks
C1	Power supply bypass capacitor	100 μ F or more	These capacitors must be placed near the V _{CC} and GND pins.
C2	Oscillation prevention capacitor	0.22 μ F or more	
C3	EXT output stabilization capacitor	2.2 μ F or more	
C4	ANT output stabilization capacitor	2.2 μ F or more	
C5, C7, C9, C11	Output stabilization capacitor	4.7 μ F or more	Electrolytic capacitor *
C6, C8, C10, C12	Output stabilization capacitor	0.22 μ F or more	Ceramic capacitor *
R1	Resistor for ILM voltage adjustment	ILM output voltage R1:without = 12.0V :270k Ω = 10.0V :100k Ω = 8.0V	A resistor with resistance accuracy as low as less than $\pm 1\%$ must be used.
R2, R3	Resistor for AUDIO voltage setting	AUDIO output voltage R2/R3:30k Ω /5.6k Ω = 8.0V :27k Ω /4.7k Ω = 8.5V :24k Ω /3.9k Ω = 9.0V	A resistor with resistance accuracy as low as less than $\pm 1\%$ must be used.
D1, D2, D3, D4	Diode for internal device breakdown protection		

*: In order to stabilize the regulator outputs, it is recommended that the electrolytic capacitor and ceramic capacitor be connected in parallel. Furthermore, the values listed above do not guarantee stabilization during the overcurrent protection operations of the regulator, so oscillation may occur during an overcurrent protection operation.

LV5680NPVC

• ILM output voltage setting method

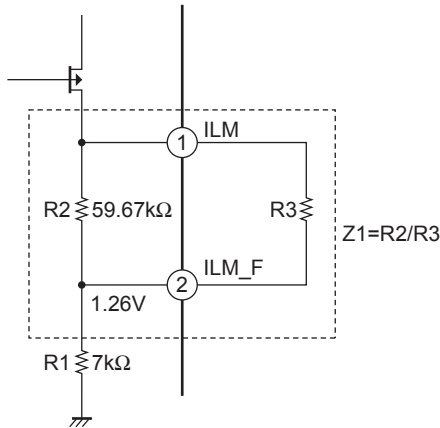

The ILM_F voltage is determined by the internal band gap voltage of the IC (typ = 1.26V).

Formula for ILM voltage calculation

$$Z_1 = R_2 // R_3 = \frac{R_2 \cdot R_3}{R_2 + R_3}$$

$$ILM = \frac{1.26[V]}{R_1} \times Z_1 + 1.26[V]$$

$$Z_1 = \frac{(ILM - 1.26) \cdot R_1}{1.26} \quad R_3 = \frac{R_2 \cdot Z_1}{R_2 - Z_1}$$

Example : ILM = 9V setting method

$$Z_1 = \frac{(9V - 1.26V) \cdot 7k\Omega}{1.26V} \cong 43k\Omega$$

$$R_3 = \frac{59.67k\Omega \cdot 43k\Omega}{59.67k\Omega - 43k\Omega} \cong 153.9k\Omega \rightarrow \boxed{150k\Omega}$$

When R3 = 150k, the ILM output voltage will be as follows:

$$Z_1' = \frac{59.67k\Omega \cdot 150k\Omega}{59.67k\Omega + 150k\Omega} \cong 42.69k\Omega$$

$$ILM = \frac{1.26V}{7k\Omega} \times 42.69k\Omega + 1.26V \cong \boxed{8.94V}$$

• AUDIO output voltage setting method

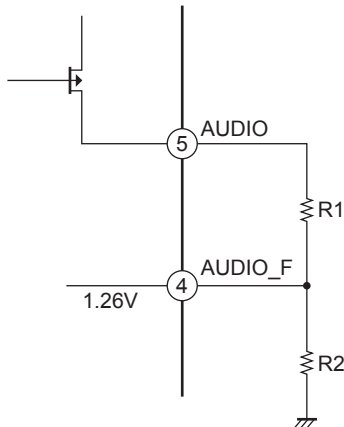

The AUDIO_F voltage is determined by the internal band gap voltage of the IC (typ = 1.26V).

Formula for AUDIO voltage calculation

$$AUDIO = \frac{1.26[V]}{R_2} \times R_1 + 1.26[V]$$

$$\frac{R_1}{R_2} = \frac{(AUDIO - 1.26)}{1.26}$$

The circuit must be designed in such a way that the R1:R2 ratio satisfies the formula given above for the AUDIO voltage that has been set.

Example : AUDIO = 8.5V setting method

$$\frac{R_1}{R_2} = \frac{(8.5 - 1.26)}{1.26} \cong 5.75$$

$$\frac{R_1}{R_2} = \frac{27k\Omega}{4.7k\Omega} \cong 5.74$$

$$AUDIO = 1.26V \times 5.74 + 1.26V \cong \boxed{8.49V}$$

Note : In the above, the typical values are given in all instances for the values used and, as such, they will vary due to the effects of production-related variations of the IC and external resistors.

LV5680NPVC

• CTRL1 Application Circuit Example

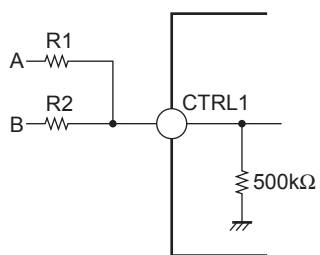

(1) 3.3V input: $R1 = 4.7k\Omega$, $R2 = 10k\Omega$

A	B	CTRL1
0V	0V	0V
0V	3.3V	1.05V
3.3V	0V	2.23V
3.3V	3.3V	3.20V

• CTRL2 Application Circuit Example

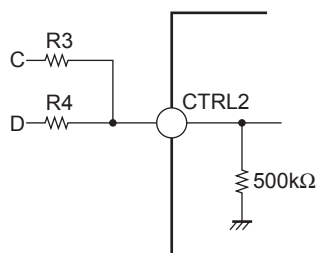

(1) 3.3V input: $R3 = R4 = 4.7k\Omega$

A	B	CTRL2
0V	0V	0V
0V	3.3V	1.61V
3.3V	0V	1.61V
3.3V	3.3V	3.29V

LV5680NPVC

HZIP15J Heat sink attachment

Heat sinks are used to lower the semiconductor device junction temperature by leading the heat generated by the device to the outer environment and dissipating that heat.

a. Unless otherwise specified, for power ICs with tabs and power ICs with attached heat sinks, solder must not be applied to the heat sink or tabs.

b. Heat sink attachment

- Use flat-head screws to attach heat sinks.
- Use also washer to protect the package.
- Use tightening torques in the ranges 39-59Ncm(4-6kgcm) .
- If tapping screws are used, do not use screws with a diameter larger than the holes in the semiconductor device itself.
- Do not make gap, dust, or other contaminants to get between the semiconductor device and the tab or heat sink.
- Take care a position of via hole .
- Do not allow dirt, dust, or other contaminants to get between the semiconductor device and the tab or heat sink.
- Verify that there are no press burrs or screw-hole burrs on the heat sink.
- Warping in heat sinks and printed circuit boards must be no more than 0.05 mm between screw holes, for either concave or convex warping.
- Twisting must be limited to under 0.05 mm.
- Heat sink and semiconductor device are mounted in parallel.
- Take care of electric or compressed air drivers
- The speed of these torque wrenches should never exceed 700 rpm, and should typically be about 400 rpm.

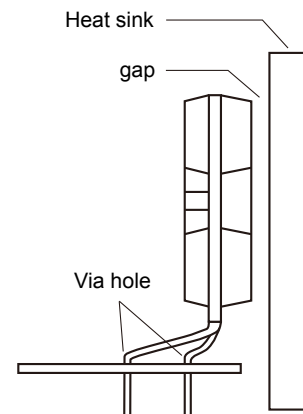
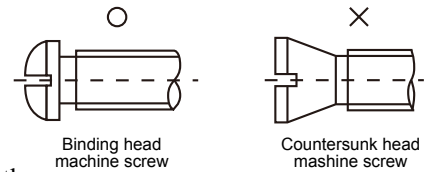

c. Silicone grease

- Spread the silicone grease evenly when mounting heat sinks.
- Our company recommends YG-6260 (Momentive Performance Materials Japan LLC)

d. Mount

- First mount the heat sink on the semiconductor device, and then mount that assembly on the printed circuit board.
- When attaching a heat sink after mounting a semiconductor device into the printed circuit board, when tightening up a heat sink with the screw, the mechanical stress which is impossible to the semiconductor device and the pin doesn't hang.

e. When mounting the semiconductor device to the heat sink using jigs, etc.,

- Take care not to allow the device to ride onto the jig or positioning dowel.
- Design the jig so that no unreasonable mechanical stress is not applied to the semiconductor device.

f. Heat sink screw holes

- Be sure that chamfering and shear drop of heat sinks must not be larger than the diameter of screw head used.
- When using nuts, do not make the heat sink hole diameters larger than the diameter of the head of the screws used. A hole diameter about 15% larger than the diameter of the screw is desirable.
- When tap screws are used, be sure that the diameter of the holes in the heat sink are not too small. A diameter about 15% smaller than the diameter of the screw is desirable.

g. There is a method to mount the semiconductor device to the heat sink by using a spring band. But this method is not recommended because of possible displacement due to fluctuation of the spring force with time or vibration.

LV5680NPVC

Caution for implementing LV5680P to a system board

The package of LV5680P is HZIP15J which has some metal exposures other than connection pins and heatsink as shown in the diagram below. The electrical potentials of (2) and (3) are the same as those of pin 15 and pin 1, respectively. (2) (=pin 15) is the V_{CC} pin and (3) (=pin 1) is the ILM (regulator) output pin. When you implement the IC to the set board, make sure that the bolts and the heatsink are out of touch from (2) and (3). If the metal exposures touch the bolts which has the same electrical potential with GND, GND short occurs in ILM output and V_{CC} . The exposures of (1) are connected to heatsink which has the same electrical potential with substrate of the IC chip (GND). Therefore, (1) and GND electrical potential of the set board can connect each other.

- HZIP15J outline

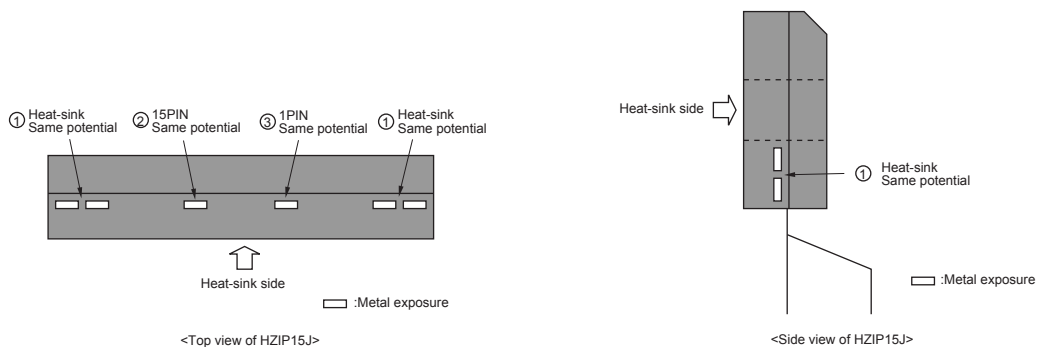

- Frame diagram (LV5680NPVC) *In the system power supply other than LV5680NPVC, pin assignment may differ.

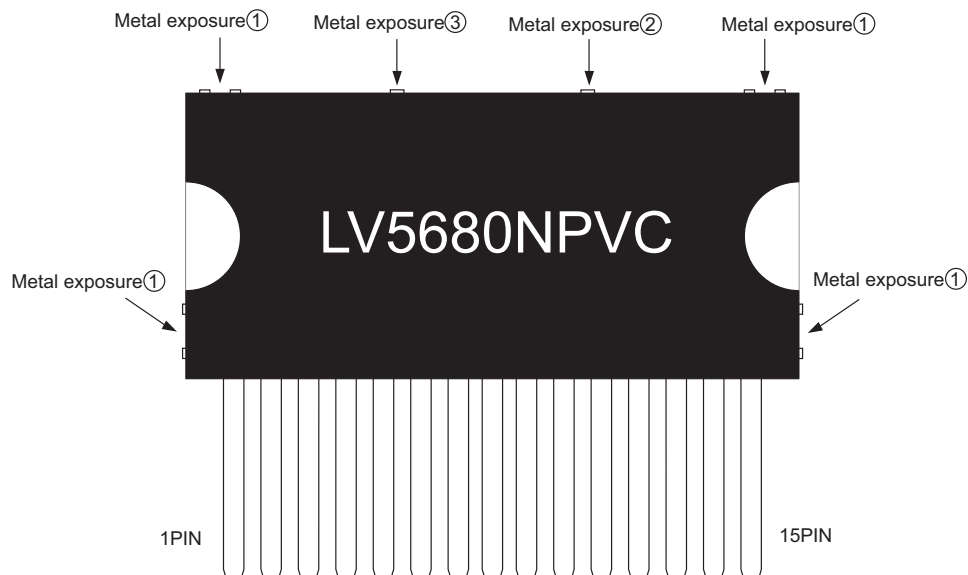

LV5680NPVC

ON Semiconductor and the ON Semiconductor logo are trademarks of Semiconductor Components Industries, LLC dba ON Semiconductor or its subsidiaries in the United States and/or other countries. ON Semiconductor owns the rights to a number of patents, trademarks, copyrights, trade secrets, and other intellectual property. A listing of ON Semiconductor's product/patent coverage may be accessed at www.onsemi.com/site/pdf/Patent-Marking.pdf. ON Semiconductor reserves the right to make changes without further notice to any products herein. ON Semiconductor makes no warranty, representation or guarantee regarding the suitability of its products for any particular purpose, nor does ON Semiconductor assume any liability arising out of the application or use of any product or circuit, and specifically disclaims any and all liability, including without limitation special, consequential or incidental damages. Buyer is responsible for its products and applications using ON Semiconductor products, including compliance with all laws, regulations and safety requirements or standards, regardless of any support or applications information provided by ON Semiconductor. "Typical" parameters which may be provided in ON Semiconductor data sheets and/or specifications can and do vary in different applications and actual performance may vary over time. All operating parameters, including "Typicals" must be validated for each customer application by customer's technical experts. ON Semiconductor does not convey any license under its patent rights nor the rights of others. ON Semiconductor products are not designed, intended, or authorized for use as a critical component in life support systems or any FDA Class 3 medical devices or medical devices with a same or similar classification in a foreign jurisdiction or any devices intended for implantation in the human body. Should Buyer purchase or use ON Semiconductor products for any such unintended or unauthorized application, Buyer shall indemnify and hold ON Semiconductor and its officers, employees, subsidiaries, affiliates, and distributors harmless against all claims, costs, damages, and expenses, and reasonable attorney fees arising out of, directly or indirectly, any claim of personal injury or death associated with such unintended or unauthorized use, even if such claim alleges that ON Semiconductor was negligent regarding the design or manufacture of the part. ON Semiconductor is an Equal Opportunity/Affirmative Action Employer. This literature is subject to all applicable copyright laws and is not for resale in any manner.